

Hierarchical Fine-Grained Image Forgery Detection and Localization

Xiao Guo, Xiaohong Liu, Zhiyuan Ren, Steven Grosz, Iacopo Masi, Xiaoming Liu
¹Michigan State University, ²Shanghai Jiao Tong University, ³Sapienza University of Roma

Poster ID: 300
Session: TUE-AM-300



MICHIGAN STATE
UNIVERSITY



SAPIENZA
UNIVERSITÀ DI ROMA

Introduction

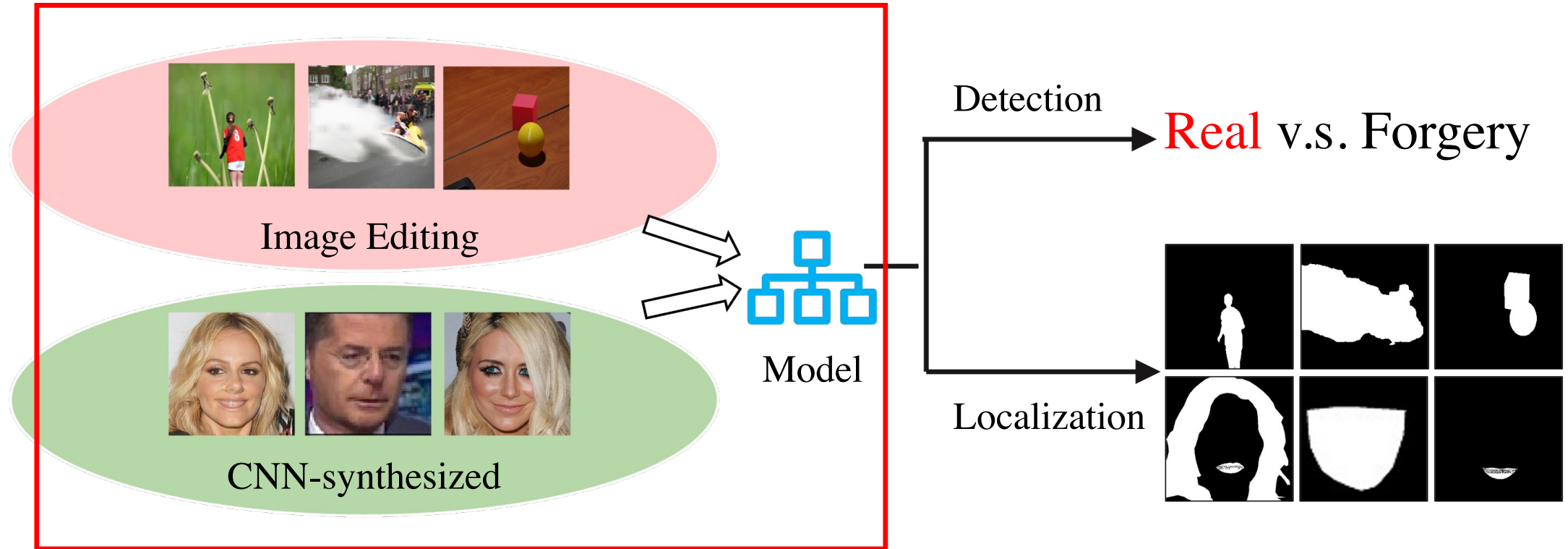

Introduction

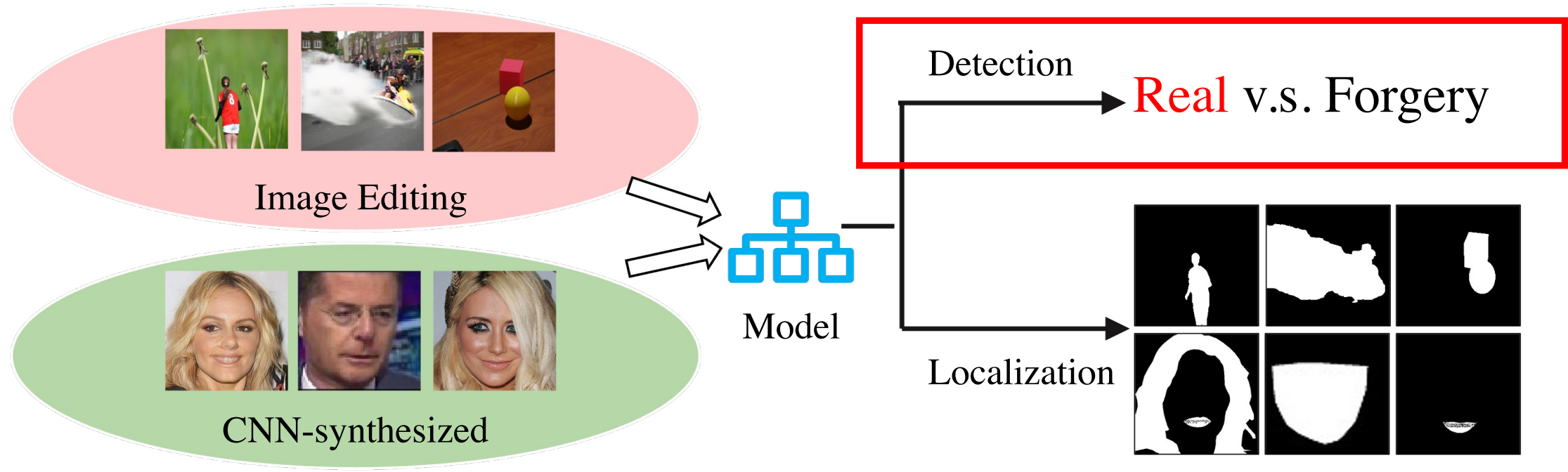

Introduction

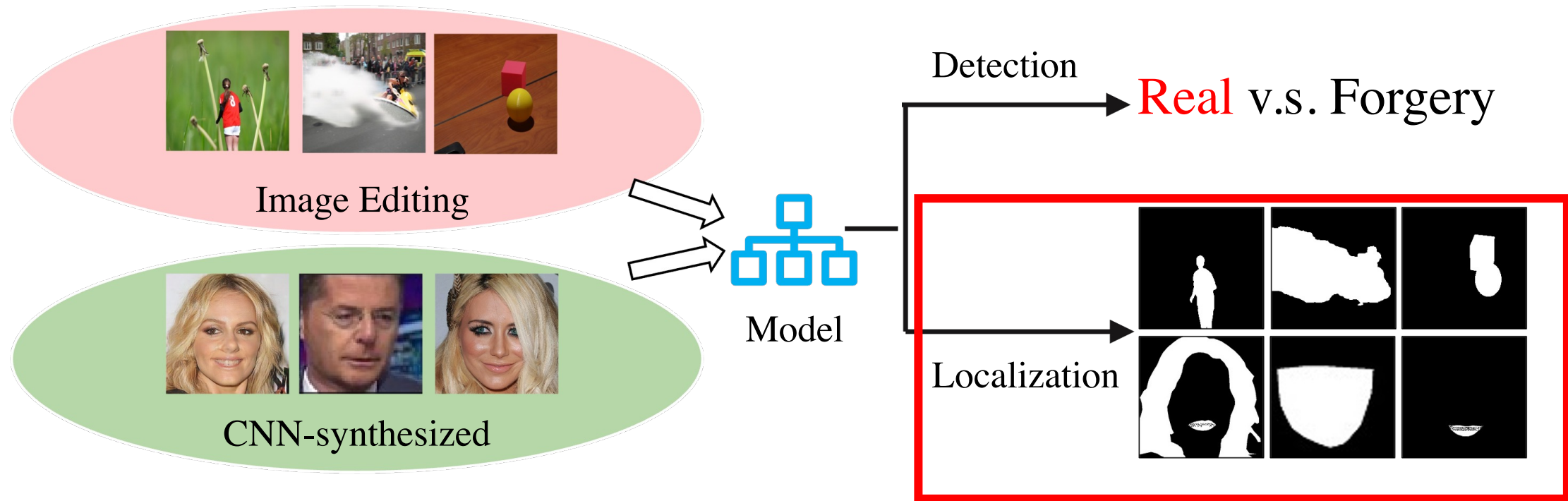
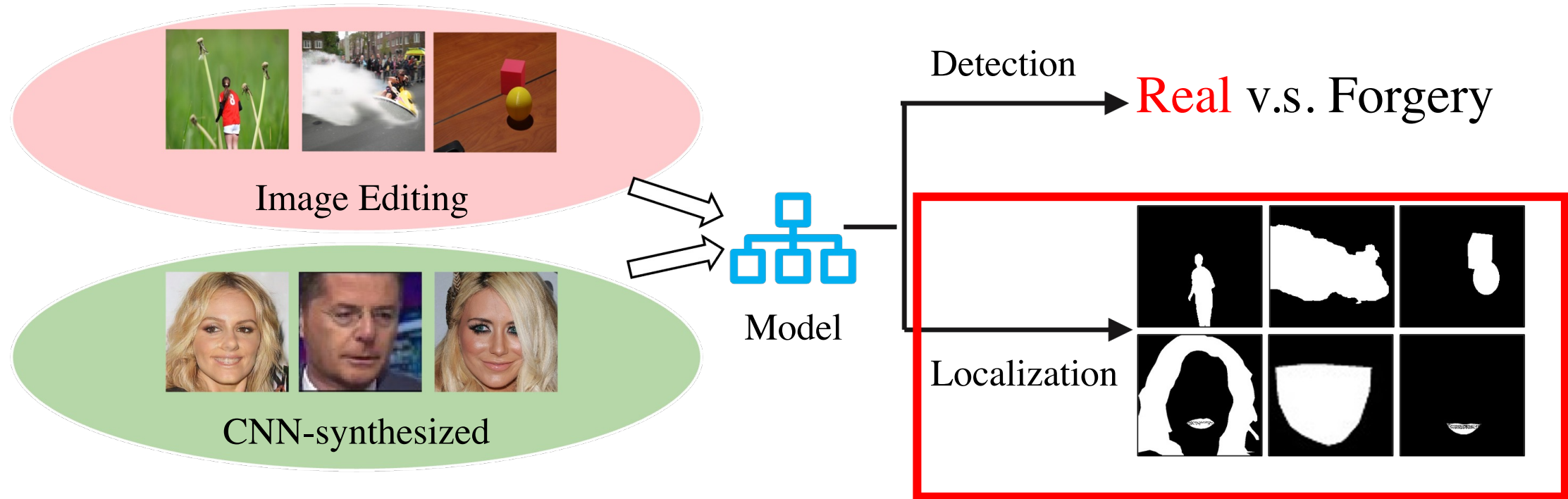

Image Forgery Detection and Localization (IFDL)



Fully or partial synthesized?

Poisson editing or GAN?

Conditional or unconditional?



In this work, we have three contributions.

- A hierarchical fine-grained formulation helps learn comprehensive representation for IFDL.
- We propose HiFi-Net, which performs well on IFDL, also identifies a diverse spectrum of forgery attributes.
- A new dataset (HiFi-IFDL) to facilitate the hierarchical fine-grained IFDL study.

Hierarchical Fine-grained Formulation

We first interpret the forgery attribute of each image

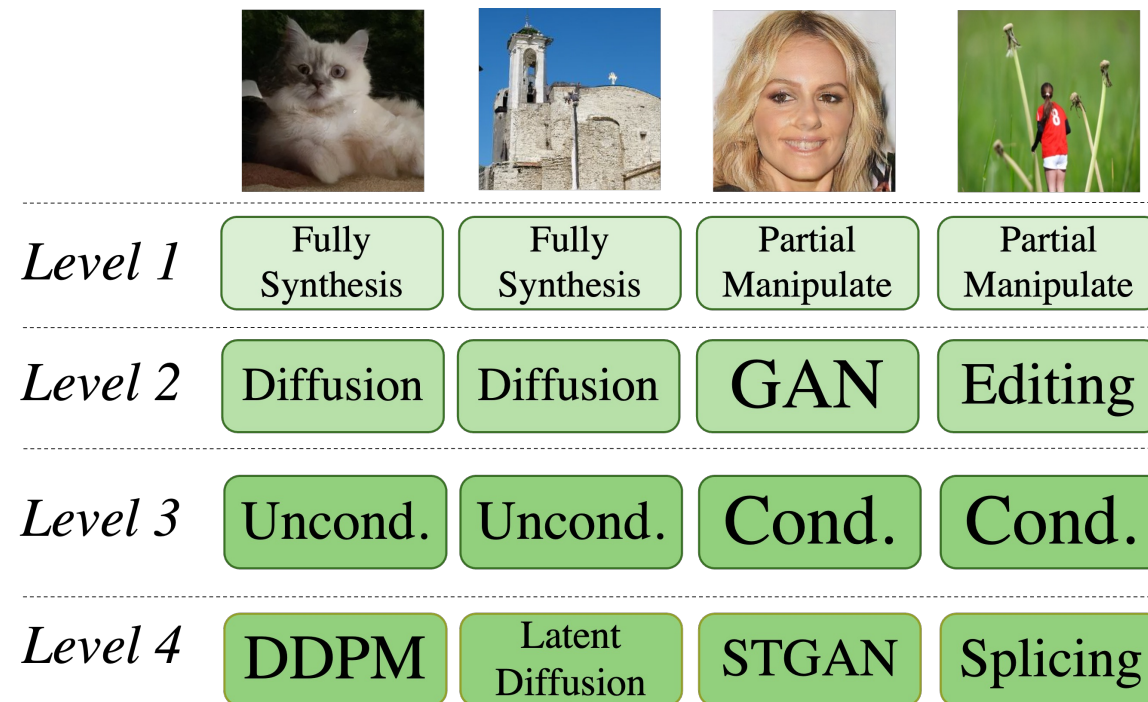

Hierarchical Fine-grained Formulation

We encourage to learn multi-level forgery attributes.

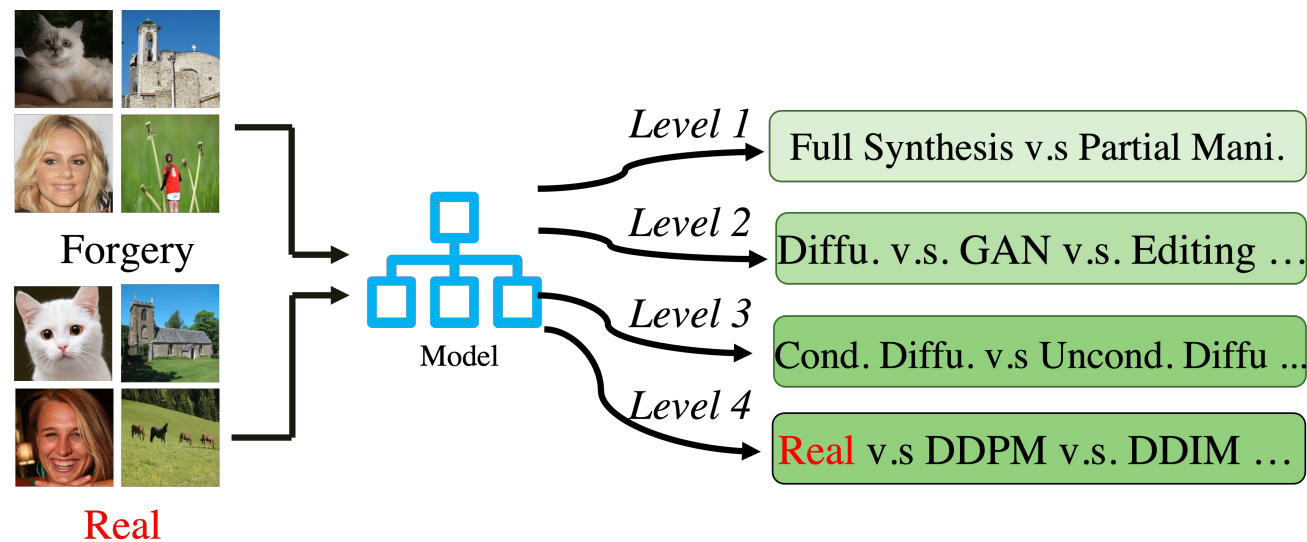
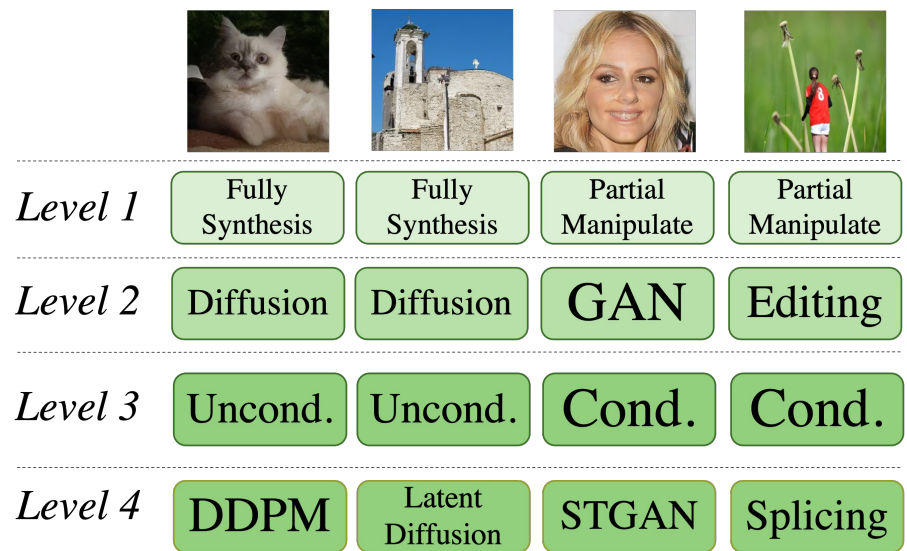

Hierarchical Fine-grained Formulation

Following the hierarchical nature.

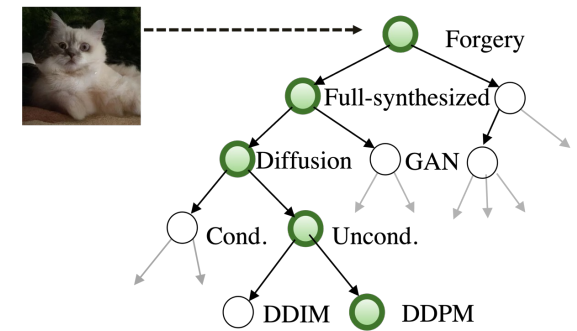
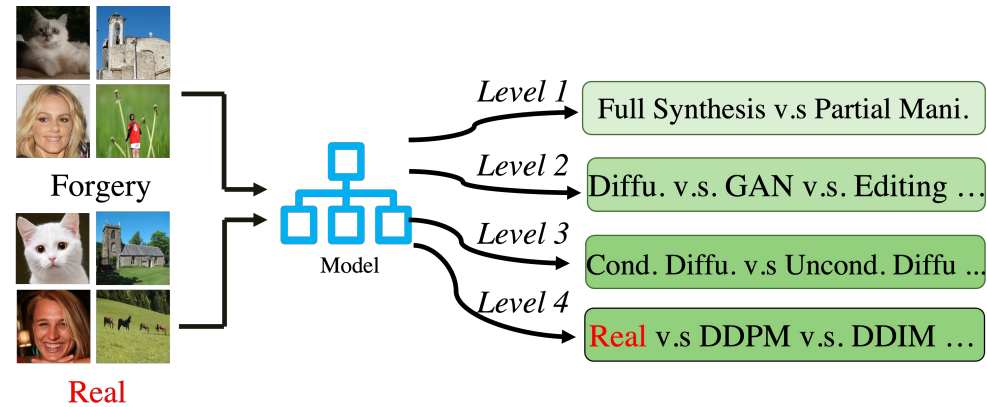
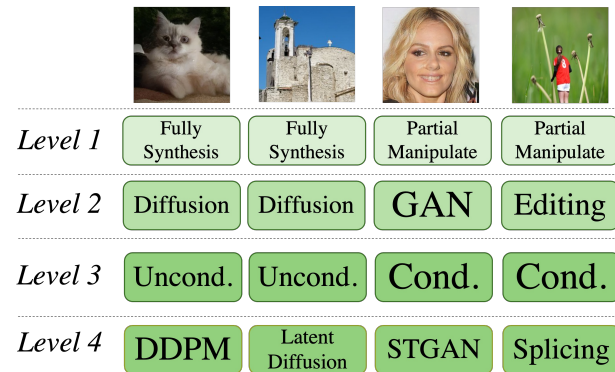

Hierarchical Fine-grained Network (HiFi-Net)

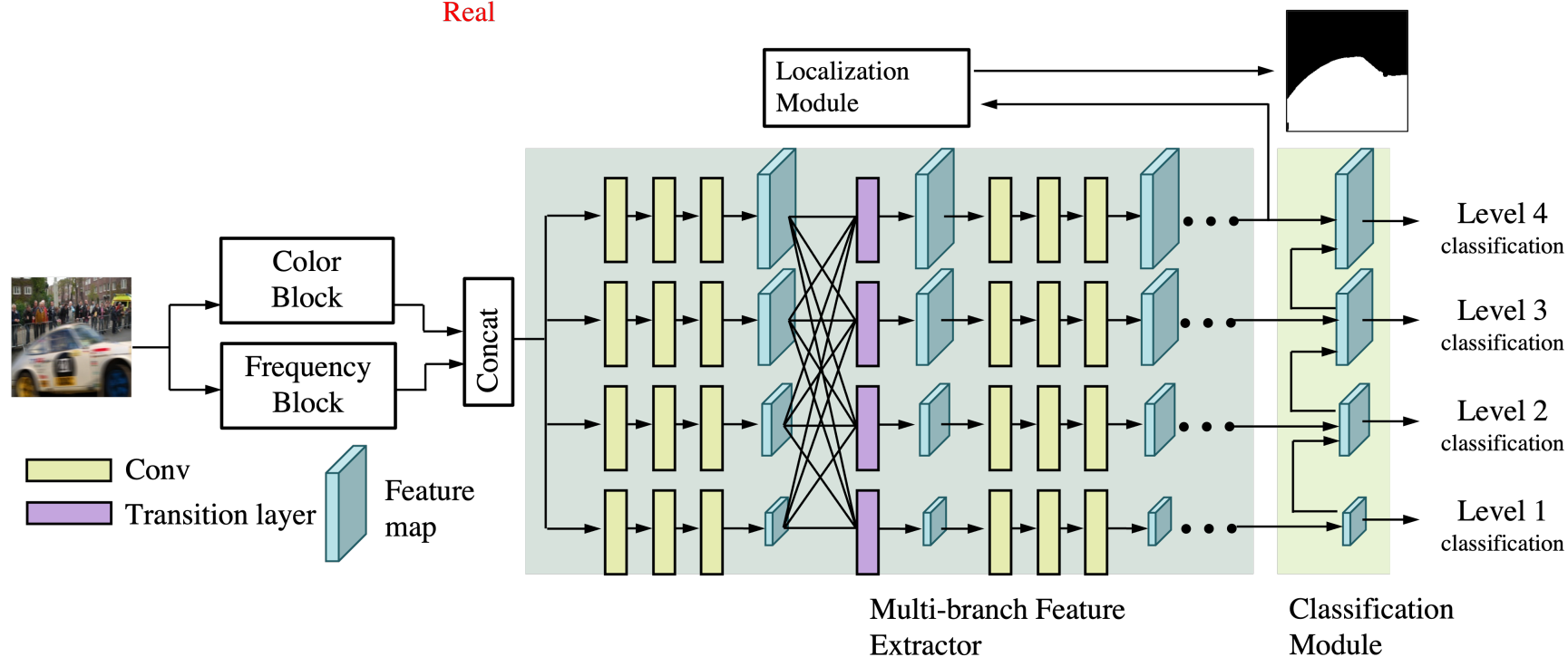
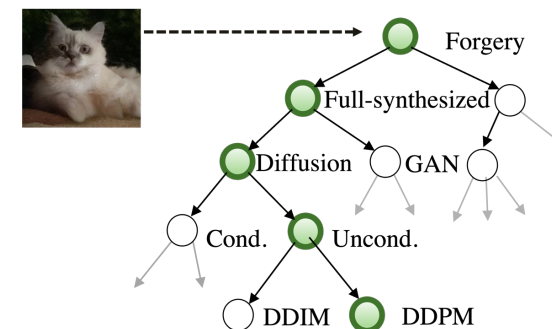
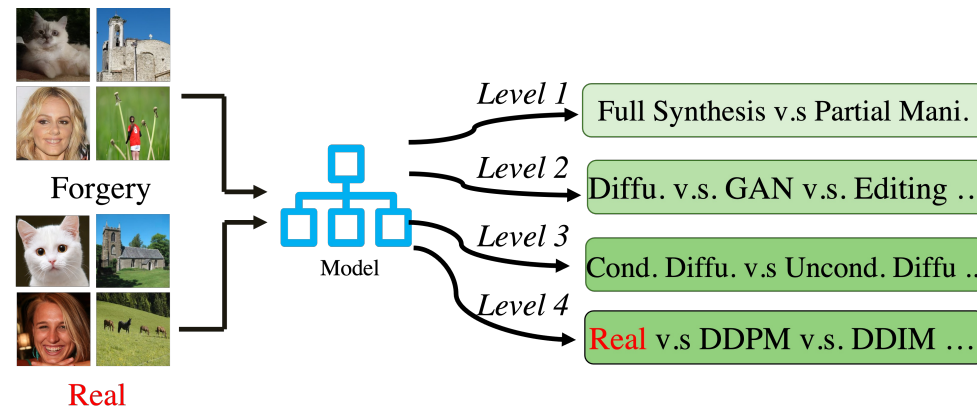
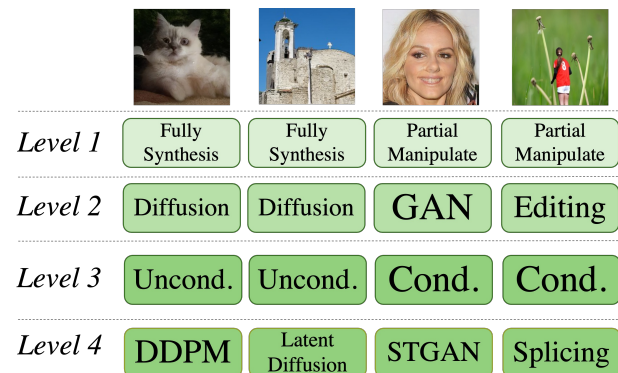

Hierarchical Fine-grained Network (HiFi-Net)

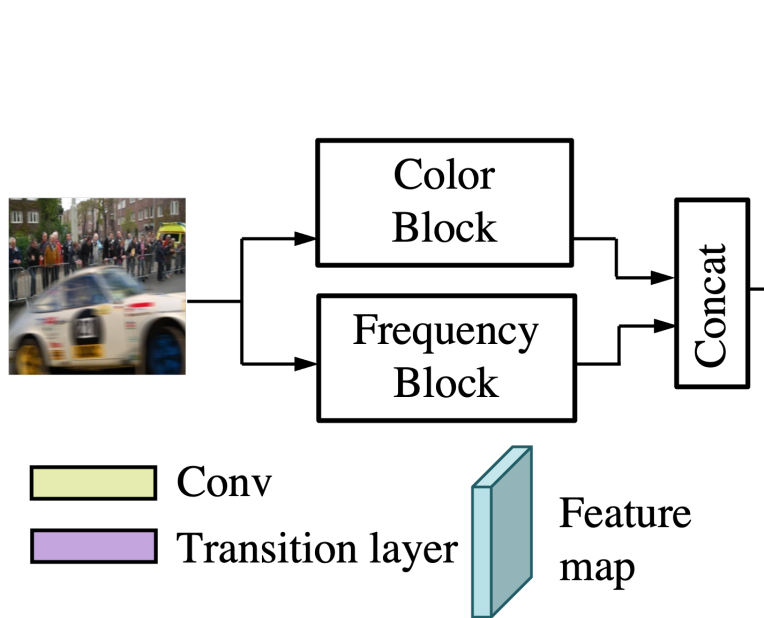

Hierarchical Fine-grained Network (HiFi-Net)

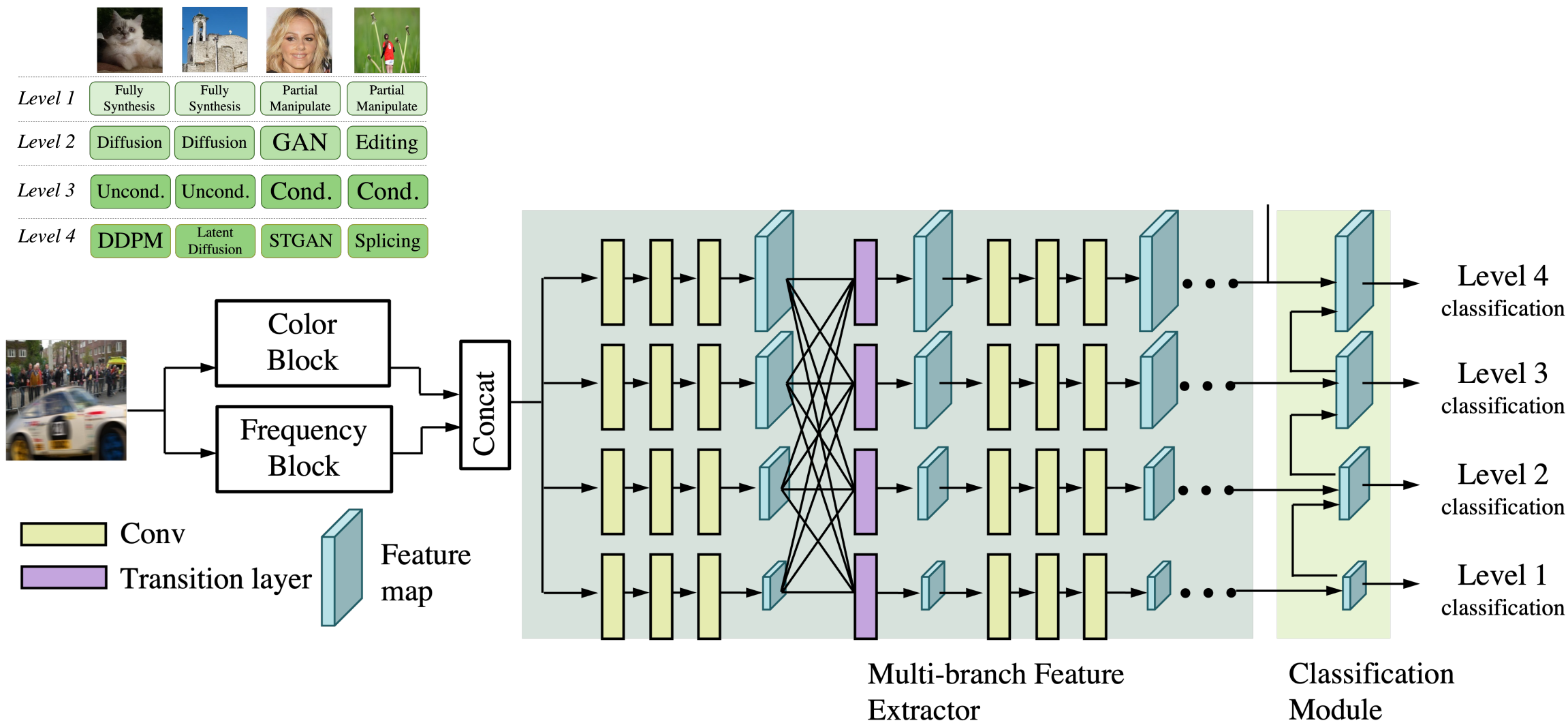

Hierarchical Fine-grained Network (HiFi-Net)

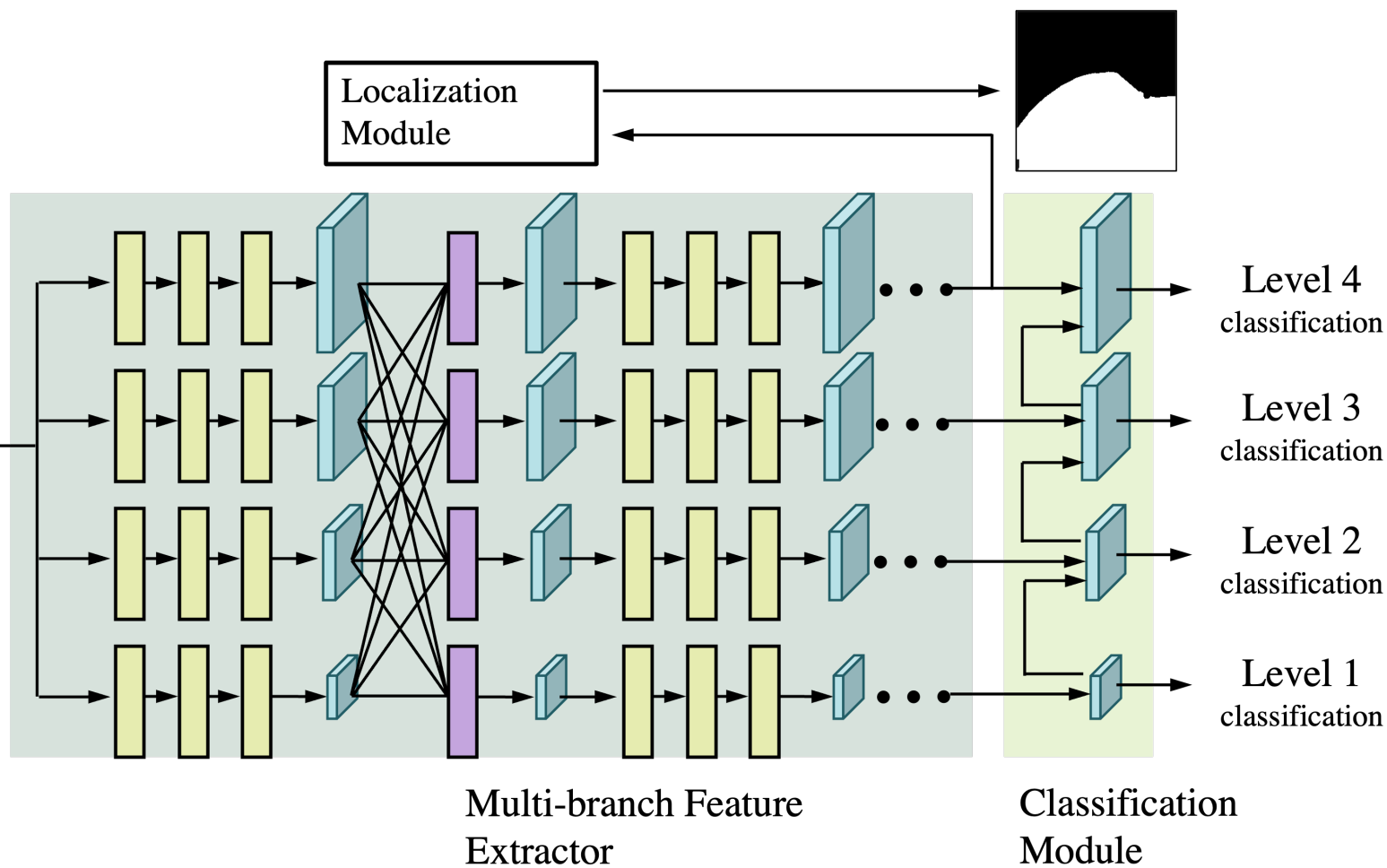
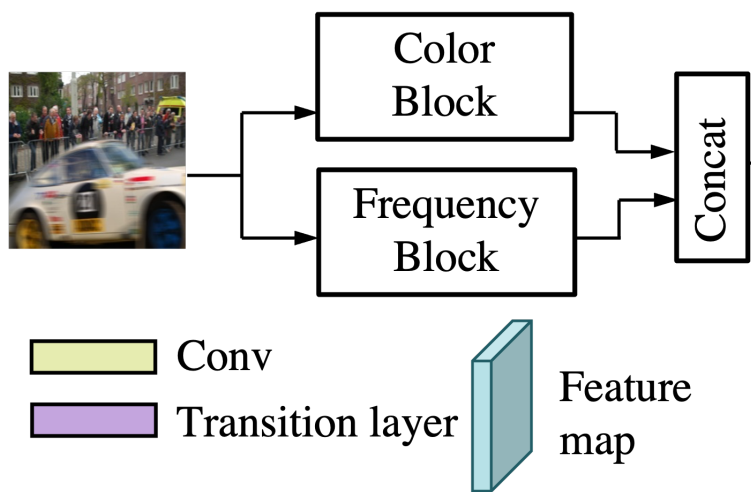
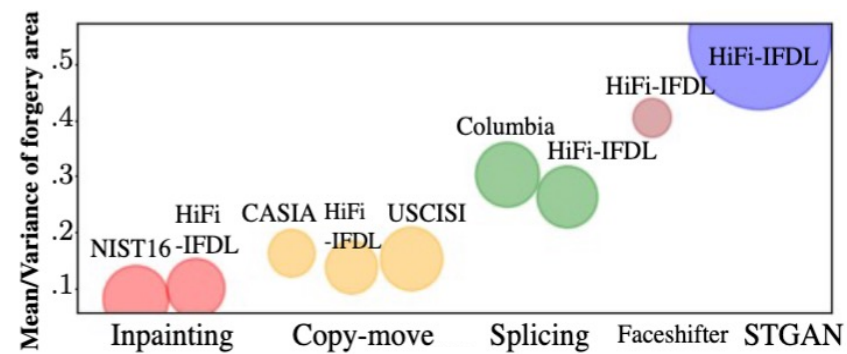

We construct a dataset to facilitate HiFi formulation.

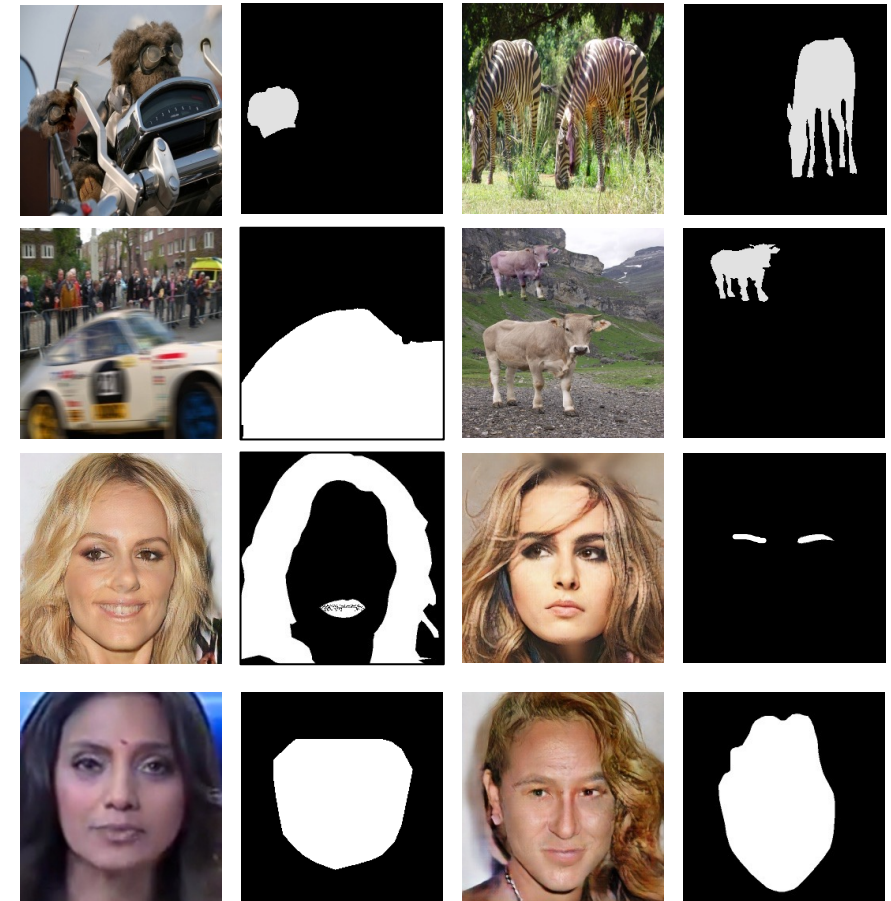
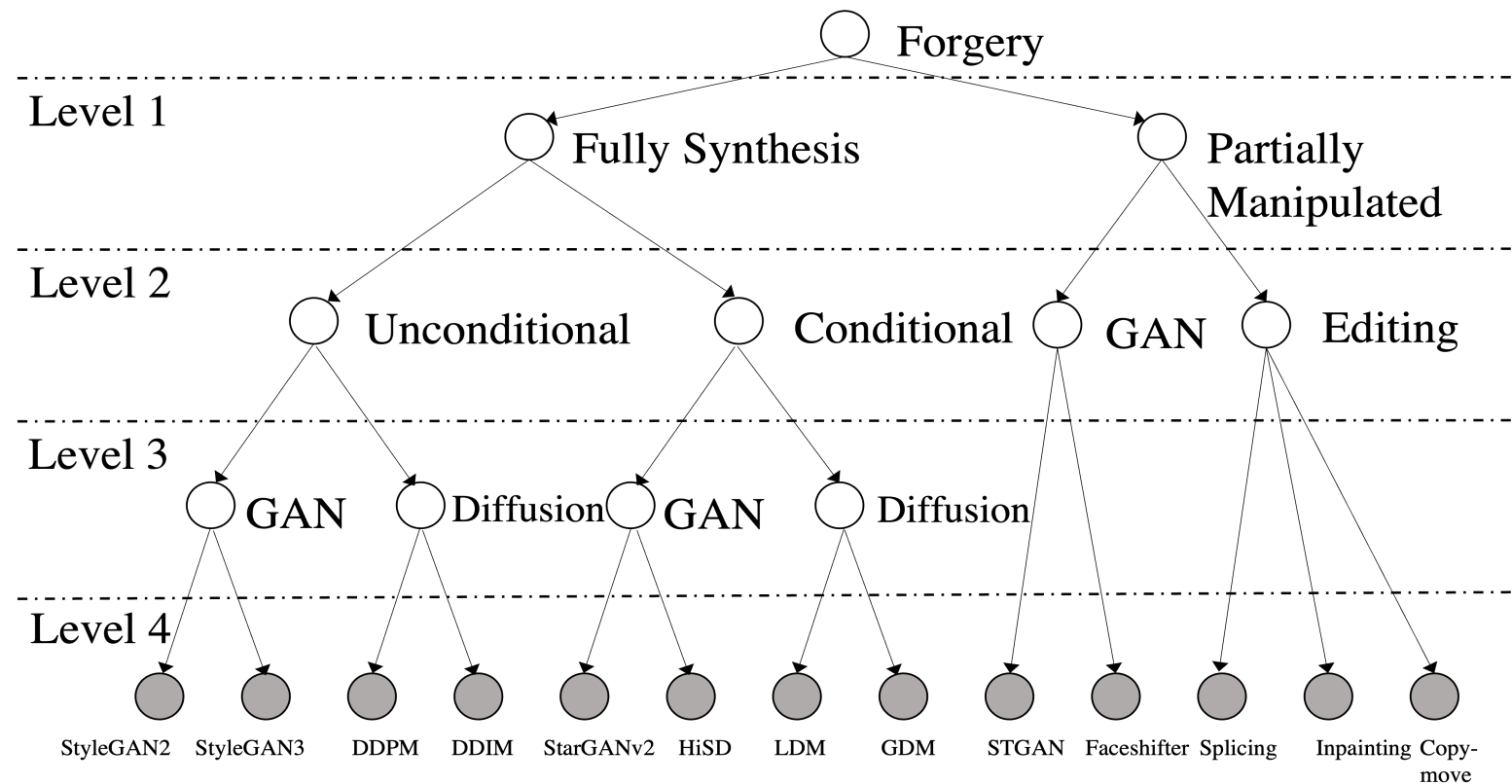

Detection and Localization performance

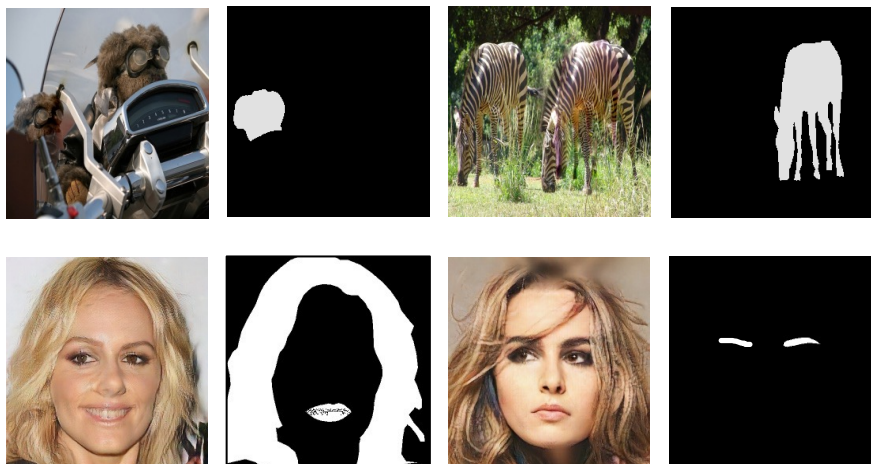
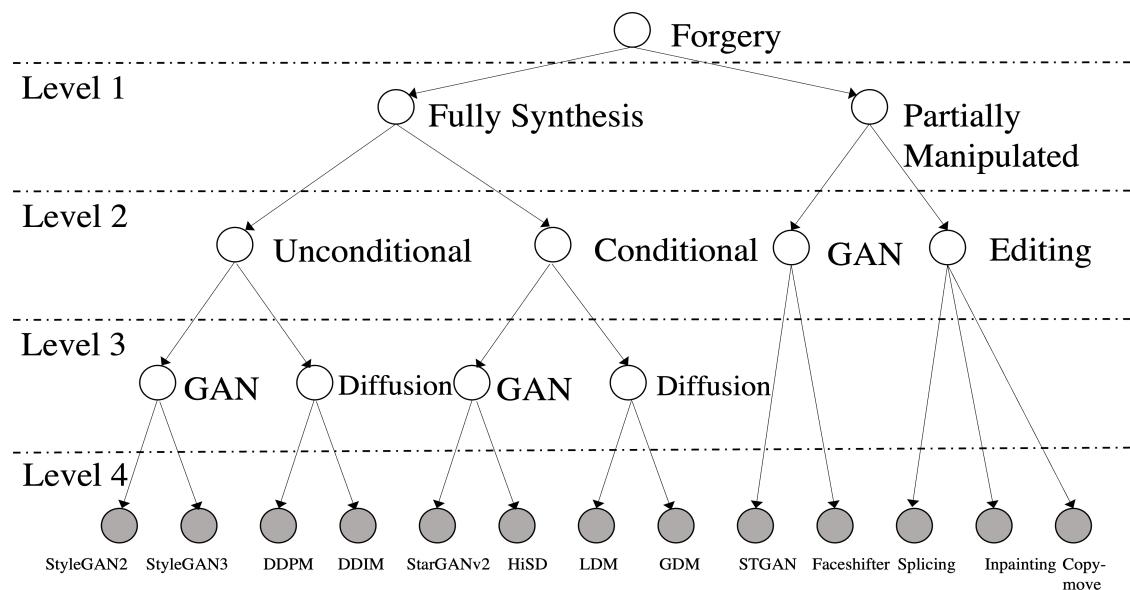

Detection Performance (F1)

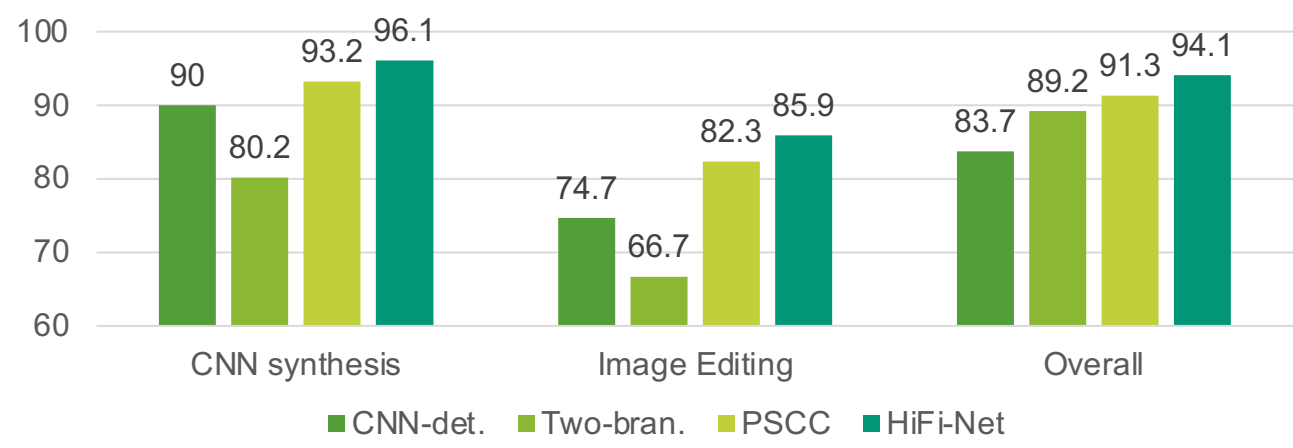

Localization Performance (F1)

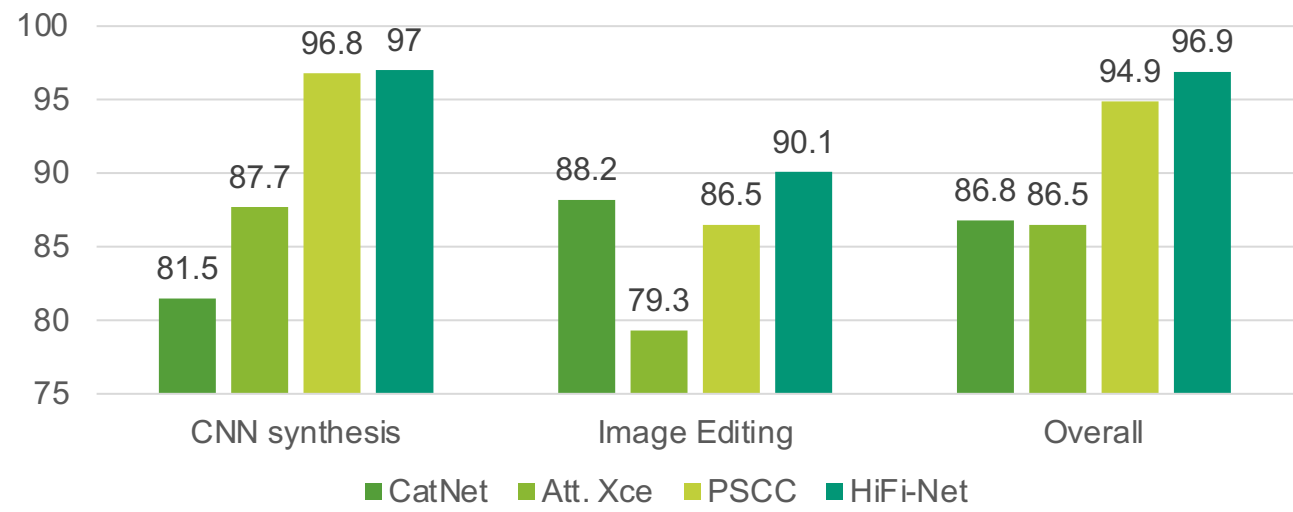

Forgery Attribute Classification

Forgery Attribute learns what forgery method used to generate the input image.

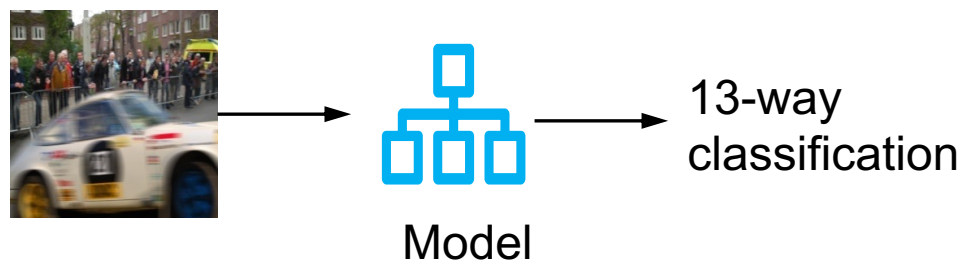

Forgery Attribute Classification

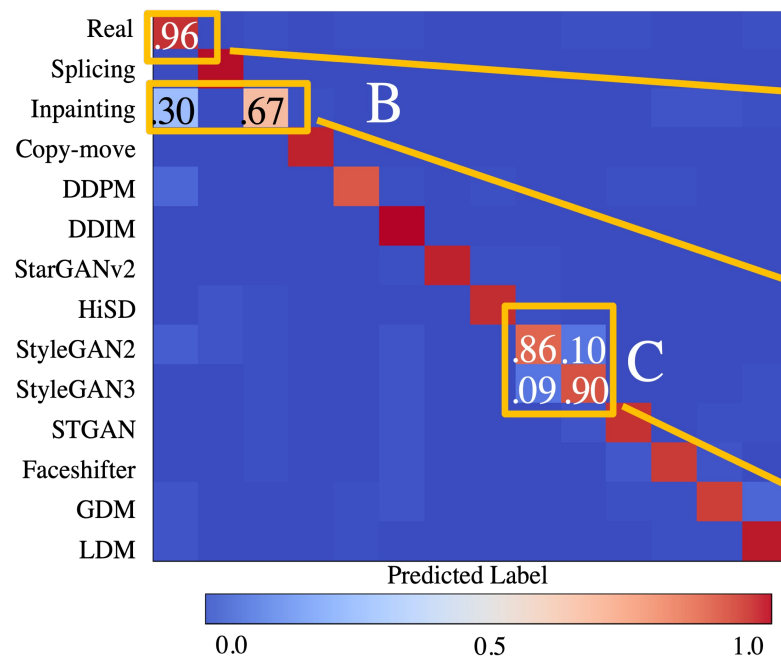
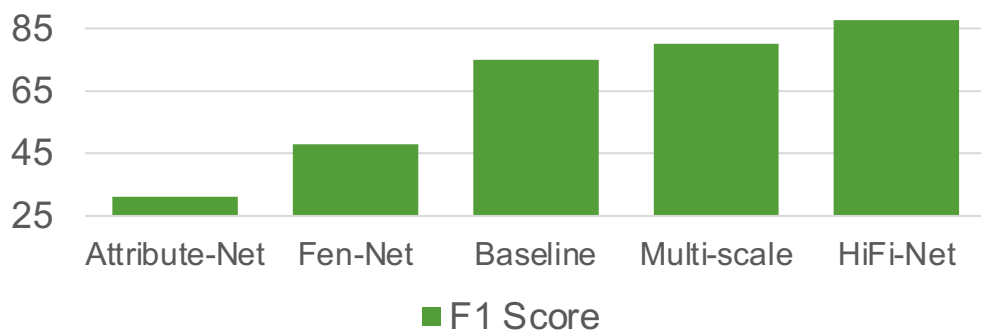

More Visualizations

More analysis on the classification and localization can be found in the poster.

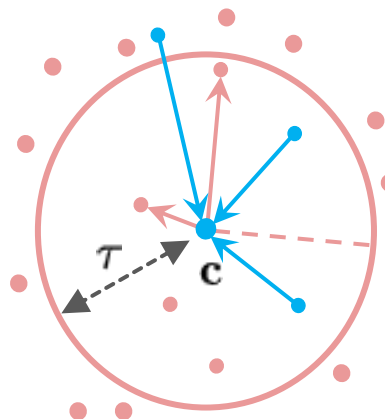
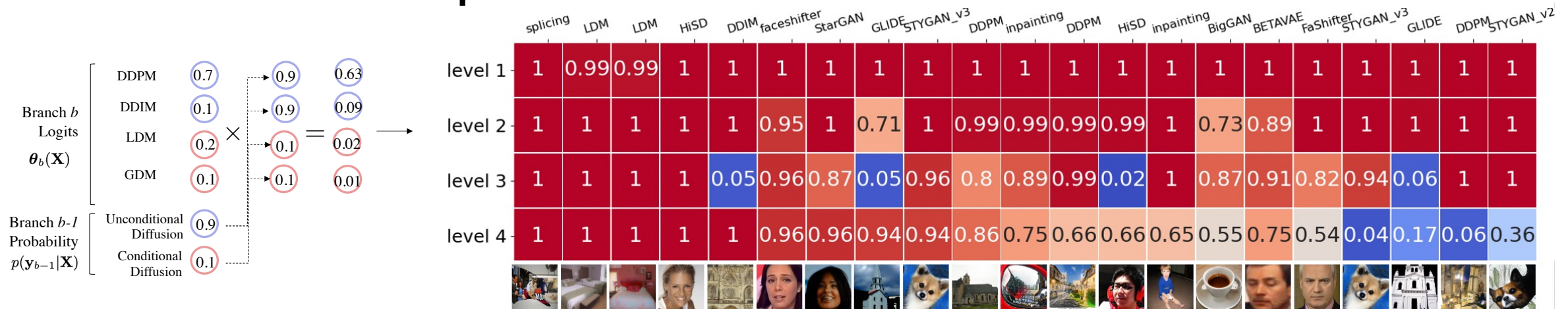

$$\mathcal{L} = \begin{cases} \| \mathbf{F}'_{ij} - \mathbf{c} \|_2 & \text{if } \mathbf{M}_{ij} \text{ real} \\ \max(0, \tau - \| \mathbf{F}'_{ij} - \mathbf{c} \|_2) & \text{if } \mathbf{M}_{ij} \text{ forged.} \end{cases}$$

\mathbf{M}_{ij} is the input pixel
 \mathbf{F}_{ij} is the input pixel feature

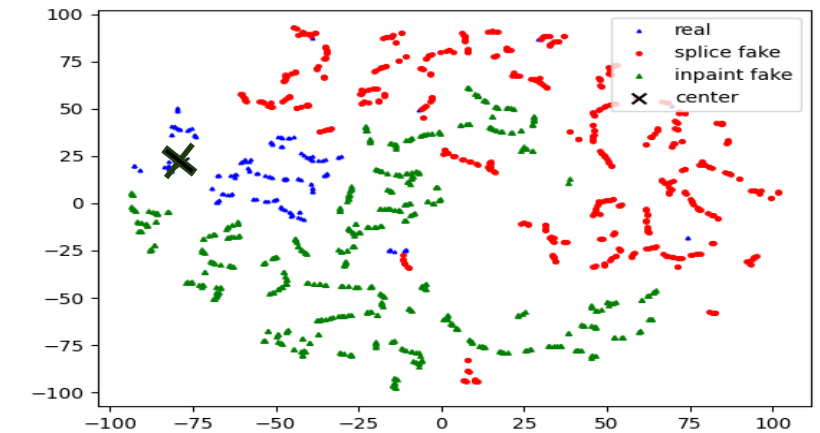

Thank You!